

PROTOCOL 14-0014

End Tidal CO₂ Testing
Panoramic Oxygen Mask
At 3% ETCO₂

Dave Piper, PE
Piper Medical Products
4807 El Camino Ave. Ste. C
Carmichael, CA 95608

The POM Study – ETCO2

PIPER MEDICAL

Protocol 14-0014

PROTOCOL: End Tidal CO₂ Testing of the POM Panoramic Oxygen Mask at 3% ETCO₂

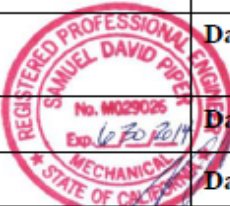
Prepared By:	S. David Piper, PE		Date:	03/19/2014
Approved By:	S. David Piper, PE		Date:	03/19/2014
Tested By:	Alex Holthaus, Brennan Rose		Date:	03/20/2014- 03/31/2014
Reported By:	S. David Piper, PE		Date:	04/01/2014
Approved By:	S. David Piper, PE		Date:	04/01/2014

1.0 Objective

- 1.1 To measure the displayed end tidal co₂ of the POM Panoramic Oxygen Mask while using a designated medium and high concentration mask adapter under simulated patient conditions and an actual end tidal CO₂ of 3%.

2.0 Reference

- 2.1 DRAFT VERSION “REVIEWER GUIDANCE FOR PREMARKET NOTIFICATION SUBMISSIONS” November 1993.
- 2.2 GOOD LABORATORY PRACTICE REGULATIONS, USFDA (21 CFR PART 58)
- 2.3 PIPER MEDICAL SOP-E-131 – PRESSURE FLOW MEASUREMENT OPERATION
- 2.4 JE COTES, DJ CHIN, AND MR MILLER., *LUNG FUNCTION*, 6TH EDITION, BLACKWELL PUBLISHING, 2006, ISBN-13:978-0-6320-6493-9
- 2.5 GL RUPPEL, *EGAN’S FUNDAMENTALS OF RESPIRATORY CARE*, 7TH EDITION, MOSBY PUBLISHING, 1999
- 2.6 WD MCADEE, F KATCH, V KATCH, *ESSENTIALS OF EXERCISE PHYSIOLOGY*, LIPPINCOTT WILLIAMS & WILKINS PUBLISHING, 2006
- 2.7 GJ TORTORA, NP ANAGNOSTAKOS, *PRINCIPLES OF ANATOMY AND PHYSIOLOGY*, 6TH EDITION, NEW YORK HARPER-COLLINS PUBLISHING, 1990, ISBN 0-06-04669-3
- 2.8 LAURALEE SHERWOOD, *FUNDAMENTAL OF PHYSIOLOGY: A HUMAN PERSPECTIVE*, THOMSON BROOKS/COLE PUBLISHING, 2006. ISBN 0-534-46697-4

PIPER MEDICAL

Protocol 14-0014

PROTOCOL: End Tidal CO₂ Testing of the POM Panoramic Oxygen Mask
at 3% ETCO₂

3.0 Acceptance Criteria

- 3.1 All equipment and laboratory processes used and specified will meet there pre-determined operation and calibration requirements before and after testing. All testing shall be performed per GLP.

4.0 Equipment List

- 4.1 POM Medical, LLC Panoramic Oxygen Mask with Medium and High concentration adapters, REF 1001 – Piper Sample ID 140317-1, 140317-2, and 140317-3
- 4.2 0-100 psig Pressure Gauge (E-008)
- 4.3 Gilmont glass float type Rotameter (E-015)
- 4.4 Low Flow Rotameter (E-082)
- 4.5 AccuLAB Standard Electronic Balance TS series (E-002)
- 4.6 Vacuum source (in-house)
- 4.7 Compressed gas source (in-house)
- 4.8 Oxygen source (in-house)
- 4.9 CO₂ source (in-house)
- 4.10 Velleman Digital Oscilloscope (E-154)
- 4.11 Ohmeda 5200 CO₂ Monitor, K843599 (E-132)
- 4.12 Data Acquisition System
- 4.13 Humidity/Temperature Meter (E-100)
- 4.14 Oxygen Sensor (E-081)
- 4.15 Harvard Respiratory Pump (E-053)
- 4.16 Wright Spirometer (E-004)
- 4.17 Mannequin Head (1.4" ID oral cavity, head width = 6.0")

The POM Study – ETCO2

PIPER MEDICAL

Protocol 14-0014

PROTOCOL: End Tidal CO2 Testing of the POM Panoramic Oxygen Mask at 3% ETCO2

Testing Procedure

5.1 Set Up

- 5.1.1 Connect the Harvard Respirator pump as shown in figure 1. Run a line from the CO2 source to the inhalation limb of the Harvard Pump on the piston side of the inhalation check valve as shown.
- 5.1.2 Use mannequin head for a simulated patient head.

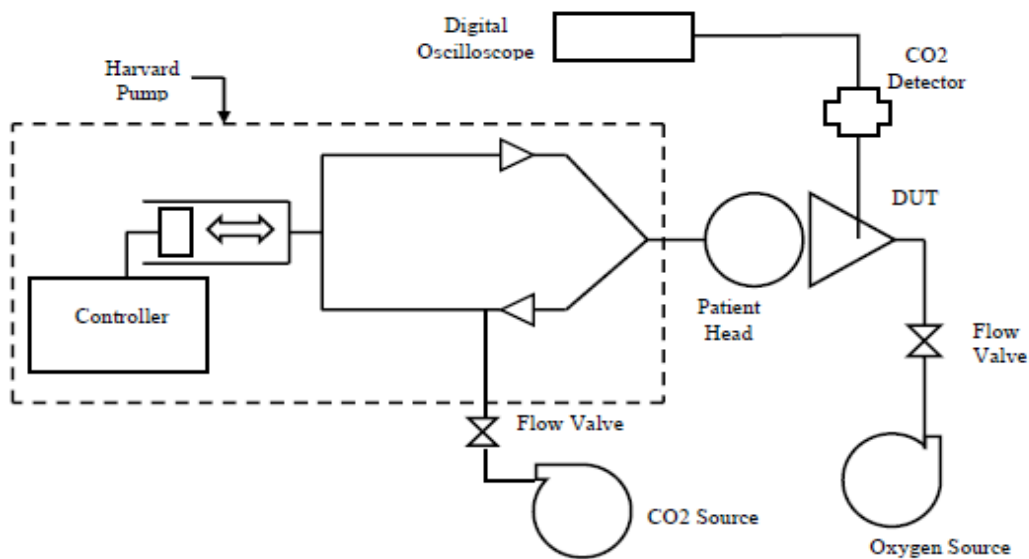

Figure 1 showing the patient simulation setup used for testing

- 5.1.3 Set the Harvard Pump and CO2 flow to the desired settings per table 1.

<u>Simulated Respiratory Settings</u>	
Respiratory Rate	12 bpm
Tidal Volume	400 ml
I:E Ratio	1:1
End Tidal CO2	3%

Table 1 showing the respiratory settings used for testing

- 5.1.4 Attach a CO2 sensing line onto DUT as described in product instructions.

PIPER MEDICAL

Protocol 14-0014

PROTOCOL: End Tidal CO₂ Testing of the POM Panoramic Oxygen Mask at 3% ETCO₂



Figure 2 showing a picture of the set ups used during testing. The medium concentration adapter configuration is showed on the left, the high concentration adapter configuration is showed on the right.

5.2 Testing

- 5.2.1 Two sets of measurements will be performed, one set will be with the sample masks equipped with a medium concentration adapter as described in the production instructions. The other identical set of tests will be performed on the same sample masks equipped with a high concentration adapter as described in the product instructions. Testing of the medium concentration adapter configuration will occur at 8, 10, and 12 l/min oxygen flow provided as described in product instructions. Testing of the high concentration adapter configuration will occur at 10, 12, and 15 l/min oxygen flow as described in the product instructions.
- 5.2.2 Each sample will be tested once in each configuration at each oxygen flow rate.
- 5.2.3 In each testing case, allow system to equilibrate for at least 3 minutes prior to taking each reading.
- 5.2.4 After allowing each setting 3 minutes to equilibrate capture a full inhalation exhalation waveform and take an end tidal co₂ measurement. Upon completion of testing there should be a combined 18 end tidal CO₂ measurements and 18 waveforms for all settings and configurations combined.
- 5.2.5 Tabulate combined data and perform a comparison.

The POM Study – ETCO2

PIPER MEDICAL

Protocol 14-0014

PROTOCOL: End Tidal CO₂ Testing of the POM Panoramic Oxygen Mask at 3% ETCO₂

RESULTS

POM (Panoramic Oxygen Mask) ET CO₂ Results
 Rate = 12 BPM, TV = 400 ml, I:E Ratio = 1:1, ETCO₂ % = 3%

Sample #	<u>ETCO₂ Measured Values</u>		
Medium Oxygen Flow Adaptor	O₂ Flow = 8 l/min	O₂ Flow = 10 l/min	O₂ Flow = 12 l/min
1	2.38%	1.66%	1.55%
2	2.24%	1.83%	1.71%
3	2.21%	1.80%	1.71%
Mean	2.28%	1.77%	1.66%
Std Dev	0.09%	0.09%	0.09%
High Oxygen Flow Adaptor	O₂ Flow = 10 l/min	O₂ Flow = 12 l/min	O₂ Flow = 15 l/min
1	1.68%	0.99%	0.73%
2	1.73%	1.12%	0.85%
3	1.79%	1.16%	0.98%
Mean	1.73%	1.09%	0.85%
Std Dev	0.05%	0.09%	0.13%

Table 2 showing end tidal CO₂ (ETCO₂) for the POM (Panoramic Oxygen Mask) under simulated patient conditions of ETCO₂ of 3%

The POM Study – ETCO2

PIPER MEDICAL

Protocol 14-0014

PROTOCOL: End Tidal CO₂ Testing of the POM Panoramic Oxygen Mask at 3% ETCO₂

POM (Panoramic Oxygen Mask) CO₂ Waveforms Under Simulated Conditions
Rate = 12 BPM, TV = 400 ml, End Tidal = 3%, I:E Ratio = 1:1

Medium Oxygen Flow Rate Adaptor
O₂ Flow = 8 l/m

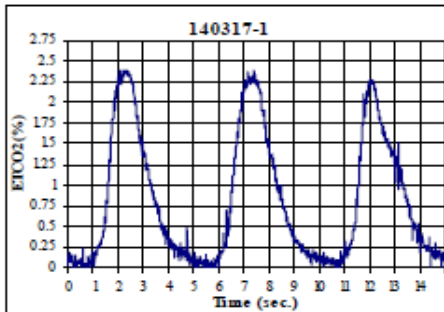

Medium Oxygen Flow Rate Adaptor
O₂ Flow = 10 l/m

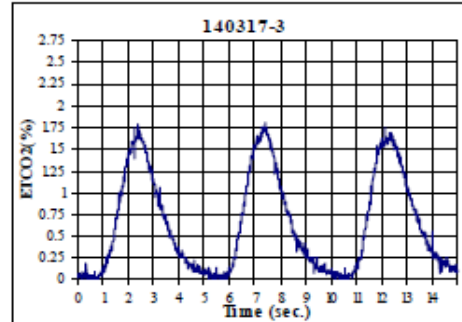
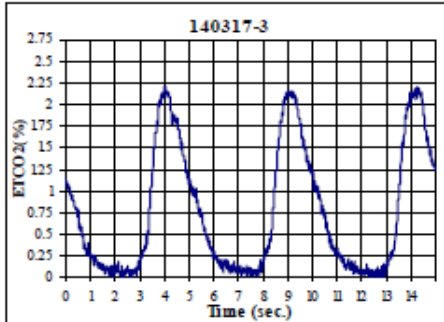
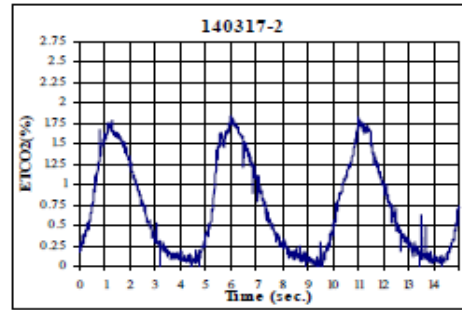
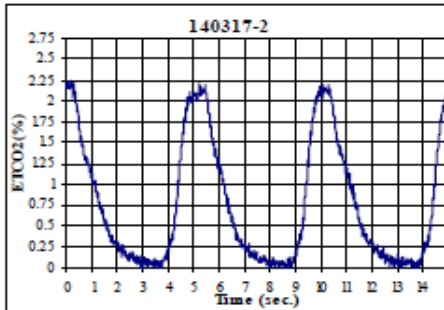
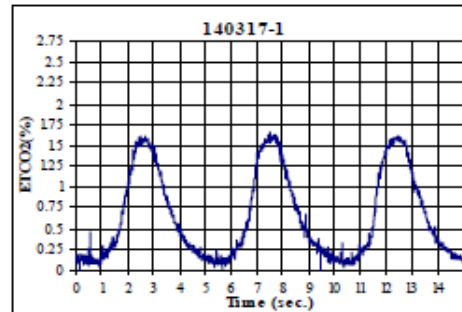

Figure 3 showing the CO₂ waveforms for the POM (Panoramic Oxygen Mask) with the Medium Flow Oxygen Adaptor

The POM Study – ETCO2

PIPER MEDICAL

Protocol 14-0014

PROTOCOL: End Tidal CO₂ Testing of the POM Panoramic Oxygen Mask at 3% ETCO₂

POM (Panoramic Oxygen Mask) CO₂ Waveforms Under Simulated Conditions
Rate = 12 BPM, TV = 400 ml, End Tidal = 3%, I:E Ratio = 1:1

Medium Oxygen Flow Rate Adaptor
O₂ Flow = 12 l/m

High Oxygen Flow Rate Adaptor
O₂ Flow = 10 l/m

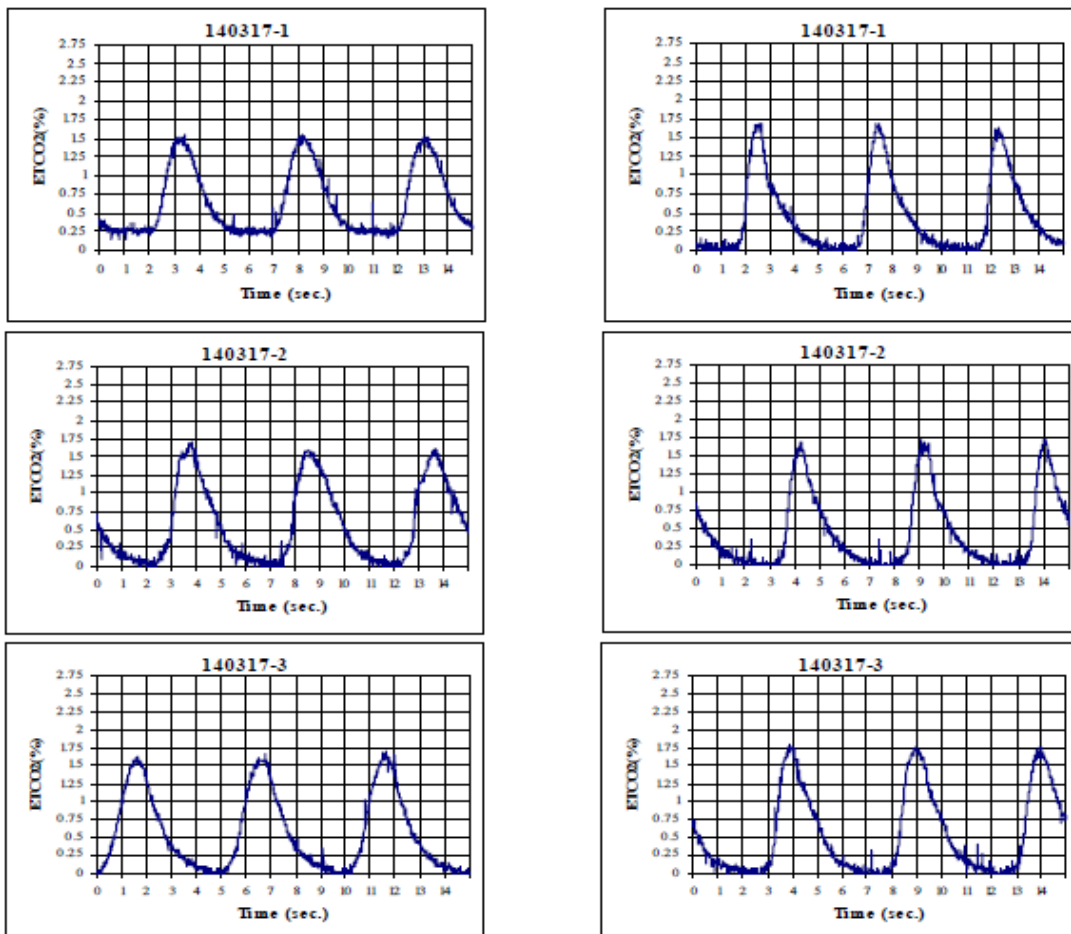

Figure 4 showing the CO₂ waveforms for the POM (Panoramic Oxygen Mask) with the Medium Flow Oxygen Adaptor and High Flow Oxygen Adaptor

The POM Study – ETCO2

PIPER MEDICAL

Protocol 14-0014

PROTOCOL: End Tidal CO₂ Testing of the POM Panoramic Oxygen Mask at 3% ETCO₂

POM (Panoramic Oxygen Mask) CO₂ Waveforms Under Simulated Conditions
Rate = 12 BPM, TV = 400 ml, End Tidal = 3%, I:E Ratio = 1:1

High Oxygen Flow Rate Adaptor
O₂ Flow = 12 l/m

High Oxygen Flow Rate Adaptor
O₂ Flow = 15 l/m

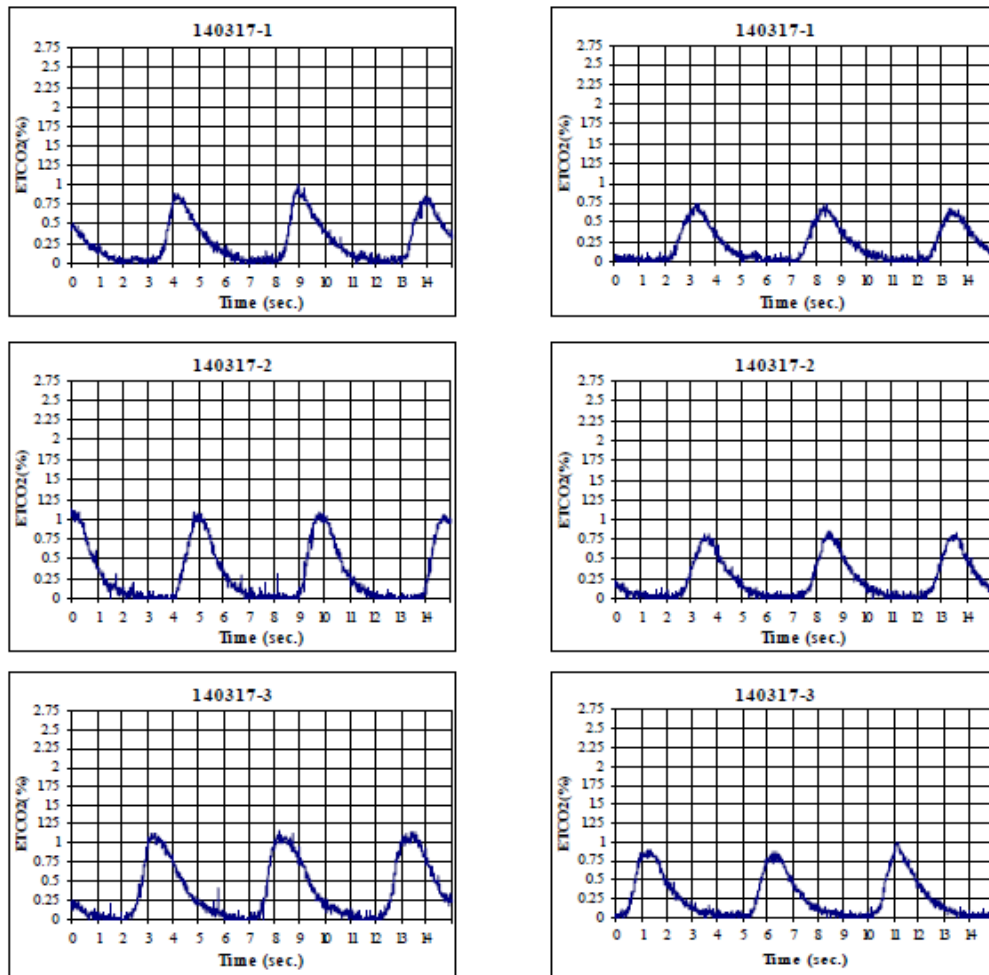

Figure 5 showing the CO₂ waveforms for the POM (Panoramic Oxygen Mask) with the High Flow Oxygen Adaptor

The POM Study – ETCO2

PIPER MEDICAL

Protocol 14-0014

PROTOCOL: End Tidal CO2 Testing of the POM Panoramic Oxygen Mask at 3% ETCO2

CO2 Waveforms Under Control Conditions
Rate = 12 BPM, TV = 400 ml, End Tidal = 3%, I:E Ratio = 1:1

Control Waveforms

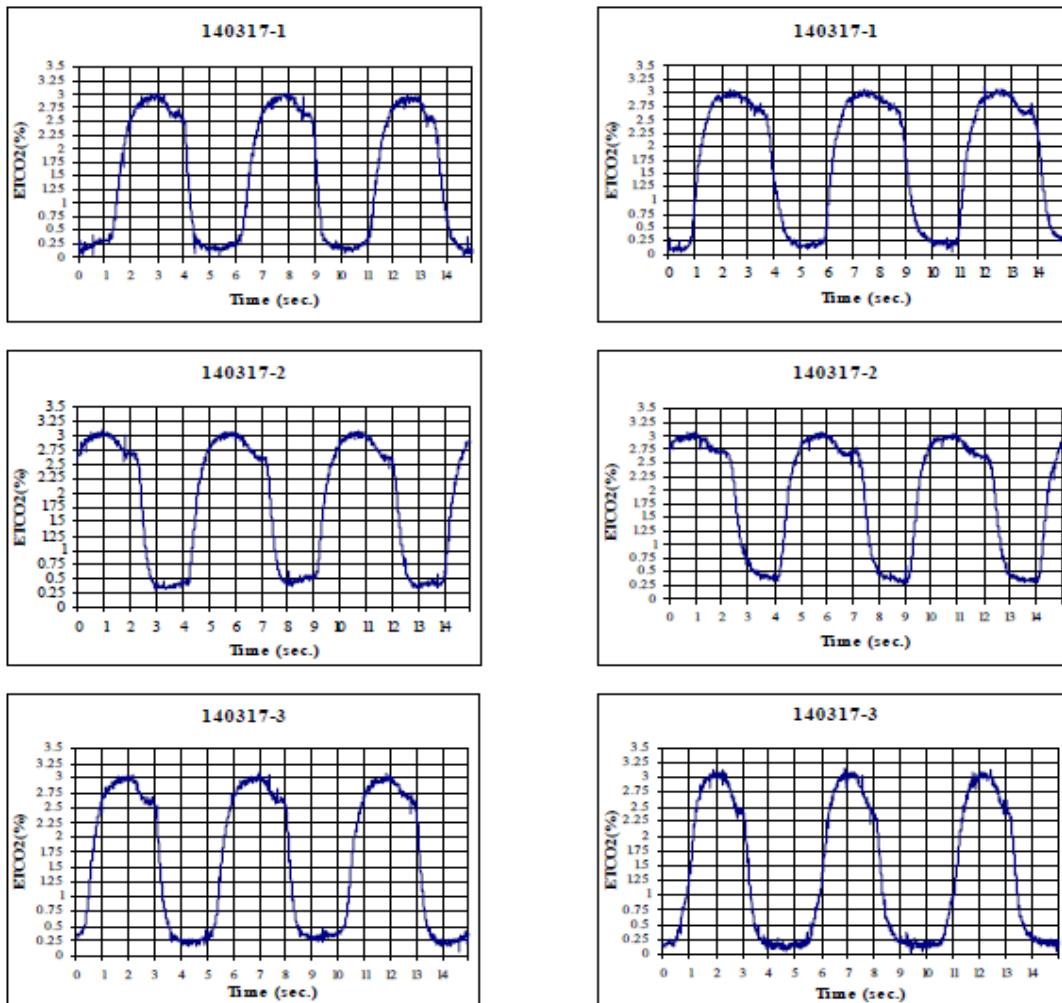

Figure 6 showing the control CO2 waveforms under control conditions

PIPER MEDICAL

Protocol 14-0014

PROTOCOL: End Tidal CO₂ Testing of the POM Panoramic Oxygen Mask
at 3% ETCO₂

DISCUSSION

All equipment and laboratory processes met there specifications and requirements before and after testing.

The Panoramic Oxygen Mask indicated actual respiration of the simulated patient. As expected, and as is normal, ET CO₂ values were reduced with increases in oxygen flow due to wash out of patient exhalation from the device.

Conclusion of Piper Medical ETCO2 Study

The results of the Piper Medical ETCO2 study of the Panoramic Oxygen Mask (POM) scientifically prove three findings about The POM and the functionality of its ETCO2 port:

1. The POM was found to function under direct scientific review
2. The findings were consistent in all testing of the mask
3. No error in functionality was derived from this study

While using the traditional suggested flow rates for any medium or high concentration oxygen mask, including the POM while simultaneously measuring capnography, the study proves the ETCO2 functionality of The POM.

It is universally accepted with any free flowing oxygen device that monitors ETCO2, that increasing flow rates will dilute the capnography wave form. The function of a ETCO2 port on devices such as The POM are not meant to act as a diagnostic in the realm of quantifying a CO2 value, rather, to detect a presence of CO2 indicating respiration.

The POM performed exceptionally in terms of allowing for the detection of CO2. It is difficult to directly compare ETCO2 functionality of a nasal cannula to an oxygen mask, however, The POM ETCO2 functionality is more consistent and sensitive because it captures expiration from both the nose and mouth as opposed to just the nose. A determination of two definitive findings when comparing these two types of devices:

- I) Delivery of a much higher fiO_2 and higher flow rates detecting ETCO2 were captured using The POM
- II) The POM is more sensitive or "accurate" in allowing the capture of ETCO2 than nasal cannulas.

It is our hope that you have found this study beneficial in examining the ETCO2 functionality of The Panoramic Oxygen Mask.

Benefits of The Panoramic Oxygen Mask

- It is a much safer alternative device than the commonly used nasal cannula. It provides more than double the FiO₂ percentage to the patient during the procedure creating increased oxygen saturation.
- Complies with the ASA guidelines for end tidal CO₂ monitoring during.
- Facilitates deeper sedation eliminating interruptions during the procedure and decreases hypoxic events.
- It is disposable reducing cross contamination and sterilization cost.
- Cost effective. It uses a simple oxygen outlet reducing the need for a circuit and ventilator as well as the need for expensive positive pressure endoscopy masks.
- Doesn't change clinical practice. It is as simple to put on as its alternative and easy to use.
- The only mask available with two anatomically placed entry points or membranes. These two modifiable membranes allow for many different size scopes, tubes, or probes.
- It is extremely versatile for many types of procedures.
- Eliminates the cumbersome maintenance of positive ventilation equipment and procedures.
- Reusable on the same patient after procedure.

